

HOOD - 3 SEATER (DRIVER & COUPÉ CONVERTIBLE).
INSTRUCTIONS FOR RAISING AND LOWERING THE HOOD.

Note:- These instructions must be adhered to or damage to the Hood is likely to occur.

LOWERING.

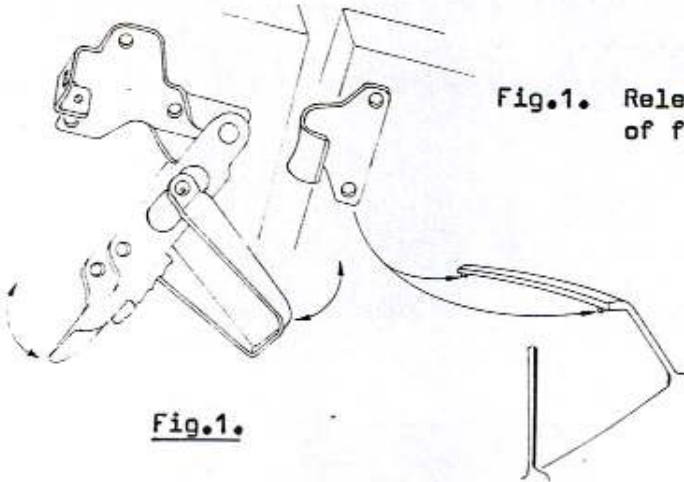

Fig.1. Release Toggle Clamps retaining both sides of front hood frame to windscreen frame.

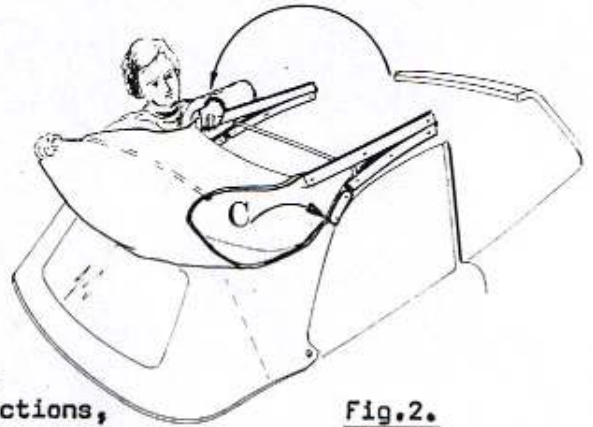

Fig.2. Fold front hood frame section over onto second and third sections, pulling material well clear back to joint C.

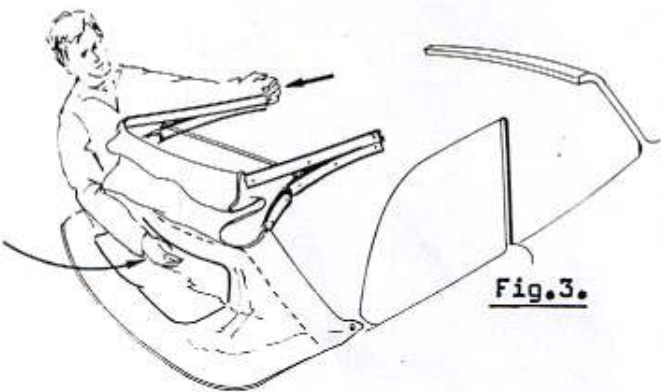

Fig.3. Push folded framework towards rear of car and down, making sure that rear window folds away neatly.

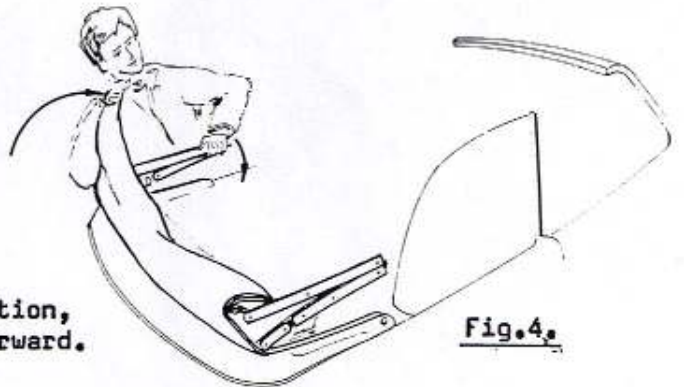

Fig.4. Push framework down past resistance into 'stowed' position, fold material of main roof forward.

(Item 5. Where 'stowing bag' is used, slip over front arms of folded, frame, enclose hood and press onto clips around rear of hood.)

RAISING.

Reverse of Lowering procedure. (Remove 'stowing bag' when used.) Fig.4. Fold material back and pull front of frame up past resistance from stowed position. Fig.3. Pull main frame (front section still folded back) up and forward to 'stop'. Fig.2. Fold front frame section over to locate at top of windscreen frame. Fig.1. Fasten both Toggle Clamps to retain hood, ensuring that they click-home into the 'lock' position.

Special Coachwork by *Avon ~ Stevens of Warwick.*

LADBROKE AVON LTD., LADBROKE HOUSE, MILLERS ROAD, WARWICK CV34 5AP, ENGLAND.
Telephone Warwick (0926) 41377/8/9.